



方型油壓缸

14MPa Hydraulic Cylinders

φ 40~φ 150

雙動油壓缸 Double actig cyliders

雙動標準型

DOUBLE ACTING - STANDARD TYPE

DHB

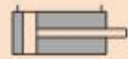

雙動雙軸型

DOUBLE ACTING - DOUBLE END ROD TYPE

DHD



- 本系列油壓缸可附緩衝

特性資料 Specification

油壓缸內徑 Bore sizes of cylinder (mm)	φ40	φ50	φ63	φ80	φ100	φ125	φ150
標準行程 Standard seroke (mm)	50 ,100 ,150 ,200 ,250 ,300 ,350 ,400 ,450 ,500						
行程範圍 The range of stroke (mm)	M ax.1500			M ax.1900			
工作媒體 Power fluid	已濾清之標準液壓油 Filtered oil						
缸管材質 Material of cylinder barrel	碳鋼管 Carbon steel STKM 13C						
使用壓力範圍 The range of pressure(M Pa)	14(140K gf/cm ²)						

使用溫度範圍 The range of temperature (°C)

- 10 ~ + 60

標示法 How to order

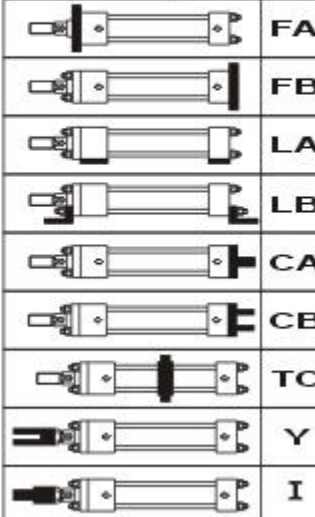
1	DHB	50	N	100	LB — Y
軸封材質 Seal material	型式 Type	內徑 Bore	緩衝位置 Cushion	行程 Stroke	配件 Accessories
	 <p>DHB DHD</p>	<p>40 — 40 mm 50 — 50 mm 63 — 63 mm 80 — 80 mm 100 — 100 mm 125 — 125 mm 150 — 150 mm</p>	<p>R: 軸端緩衝 H: 尾端緩衝 B: 兩端緩衝 N: 無緩衝 R: Rod end with cushion H: End end with cushion B: Both end with cushion N: No cushion</p>	<p>50 — 50 mm 100 — 100 mm 150 — 150 mm 200 — 200 mm 250 — 250 mm 300 — 300 mm 350 — 350 mm 400 — 400 mm 450 — 450 mm 500 — 500 mm</p>	 <p>FA FB LA LB CA CB TC Y I</p>

代號 Symbol	材質 Seal material	適用作動油種類 Kind of fluid				
		一般礦物性作動油 Petroleum - Based fluid	水乙二醇 Water - Glycol fluid	磷酸鹽油 Phosphate - Ester fluid	W/O作動油 Water in oil fluid	O/W作動油 Oil in water fluid
1	NBR Nitrile rubber	○	○	×	○	○
2	PU Polyurethane rubber	○	×	×	△	△
3	VITON Fluoro elastomer	○	×	○	○	○

備註：○允許使用 ×不允許使用 △請與我們洽詢
Note: ○allowable ×unallowable △consult us

標準製作行程 Standard stroke

unit :
mm

Bore	50	100	150	200	250	300	350	400	450	500
φ40	●	●	●	●	●	●	-	-	-	-

φ50	●	●	●	●	●	●	-	-	-	-
φ63	●	●	●	●	●	●	●	●	●	●
φ80	●	●	●	●	●	●	●	●	●	●
φ100	●	●	●	●	●	●	●	●	●	●
φ125	●	●	●	●	●	●	●	●	●	●
φ150	●	●	●	●	●	●	●	●	●	●

註：非標準行程可訂製 Note May to order of unstandard stroke

行程公差表	Stroke tolerance					
行程 stroke	~100	101 ~ 250	251 ~ 630	631 ~ 1000	1001 ~ 1600	1601 ~ 2000
公差	+0.8	+1.0	+1.25	+1.4	+1.6	+1.8
Tolerance	0	0	0	0	0	0

理論出力表		Theoretic force		操作壓力 Operating pressure (M Pa)								
缸徑 Bore (mm)	軸徑 Rod (mm)	受壓面積 Area (mm ²)										
			6	7	8	9	10	11	12	13	14	
φ40	φ20	A	1256	7.54	8.79	10.05	11.30	12.56	13.82	15.07	16.33	17.58

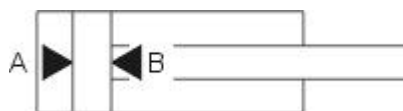

unit : KN

		B	942	5.65	6.59	7.54	8.48	9.42	10.36	11.30	12.25	13.19
φ50	φ25	A	1963	11.78	13.74	15.70	17.67	19.63	21.59	23.56	25.52	27.48
		B	1472	8.83	10.30	11.78	13.25	14.72	16.19	17.66	19.14	20.61
φ63	φ35	A	3116	18.70	21.81	24.93	28.06	31.18	34.28	37.39	40.51	43.62
		B	2154	12.92	15.08	17.23	19.39	21.54	23.69	25.85	28.00	30.16
φ80	φ40	A	5024	30.14	35.17	40.19	45.22	50.24	55.26	60.29	65.31	70.34
		B	3768	22.61	26.38	30.14	33.91	37.68	41.45	42.22	48.98	52.75
φ100	φ50	A	7850	47.10	54.95	62.80	70.65	78.50	86.35	94.20	102.05	109.90
		B	5887	35.32	41.21	47.10	52.98	58.87	64.76	70.64	76.53	82.42
φ125	φ60	A	12266	73.60	85.86	98.13	110.39	122.66	134.93	147.19	159.46	171.72
		B	9440	56.64	66.08	75.52	84.96	94.40	103.84	113.28	122.72	132.16
φ150	φ80	A	17662	105.97	123.63	141.30	158.96	176.62	194.28	211.94	229.61	247.27
		B	12638	75.83	88.47	101.10	113.74	126.38	139.02	151.66	164.29	176.93

油壓缸出力計算方式 The method of calculation (Hydraulic cylinders' force)

$$F = P \times A - f$$

F: 油缸出力 Cylinders' force (N)
P: 使用壓力 Operating pressure (MPa)
A: 截面積 Piston area (mm²)
f: 摩擦阻力 Friction drag (N)

訂購方式 How to order the seal kit

DHBSK

Bore	Seal kit
40	DHBSK 40 - Including No.13,14,15,16,17,18
50	DHBSK 50 - Including No.13,14,15,16,17,18
63	DHBSK 63 - Including No.13,14,15,16,17,18
80	DHBSK 80 - Including No.13,14,15,16,17,18
100	DHBSK 100 - Including No.13,14,15,16,17,18
125	DHBSK 80 - Including No.13,14,15,16,17,18
150	DHBSK 100 - Including No.13,14,15,16,17,18

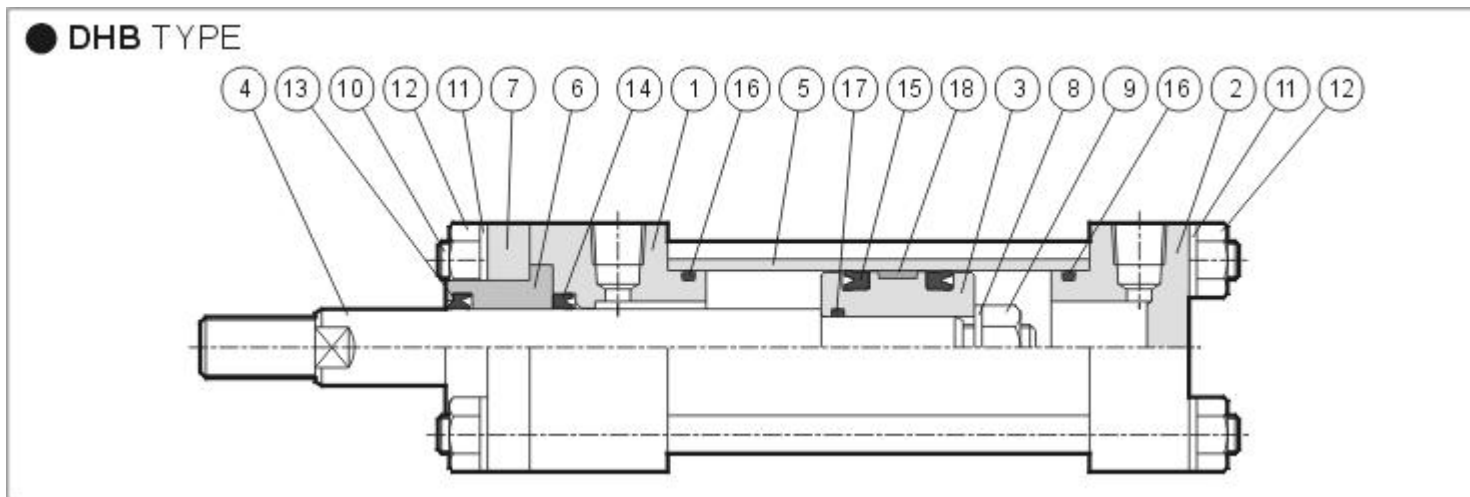

Parts List

No.	零件名稱 Part name	數量 Quantity	No.	零件名稱 Part name	數量 Quantity
1	前蓋 Rod cover	1	10	繫緊螺絲 Tie bolt	4
2	後蓋 Head cover	1	11	彈簧墊圈 Spring washer	8
3	活塞本體 Piston	1	12	螺帽 Nut	8
4	活塞桿 Piston rod	1	13	灰塵刮刷環 Dustwiper	1
5	油缸本體 Cylinder tube	1	14	前蓋U 迫緊 Rod packing	1
6	軸桿襯套 Rod bush	1	15	活塞U 迫緊 Piston packing	2
7	壓板 End plate	1	16	前後蓋O 型環 Cylinder gasket	2
8	彈簧墊圈 Spring washer	1	17	活塞O 型環 Piston gasket	1

9	活塞固定螺帽 Piston nut	1	18	耐磨環 Wearing ring	1
---	-------------------	---	----	------------------	---

外形尺寸 Dimensional features

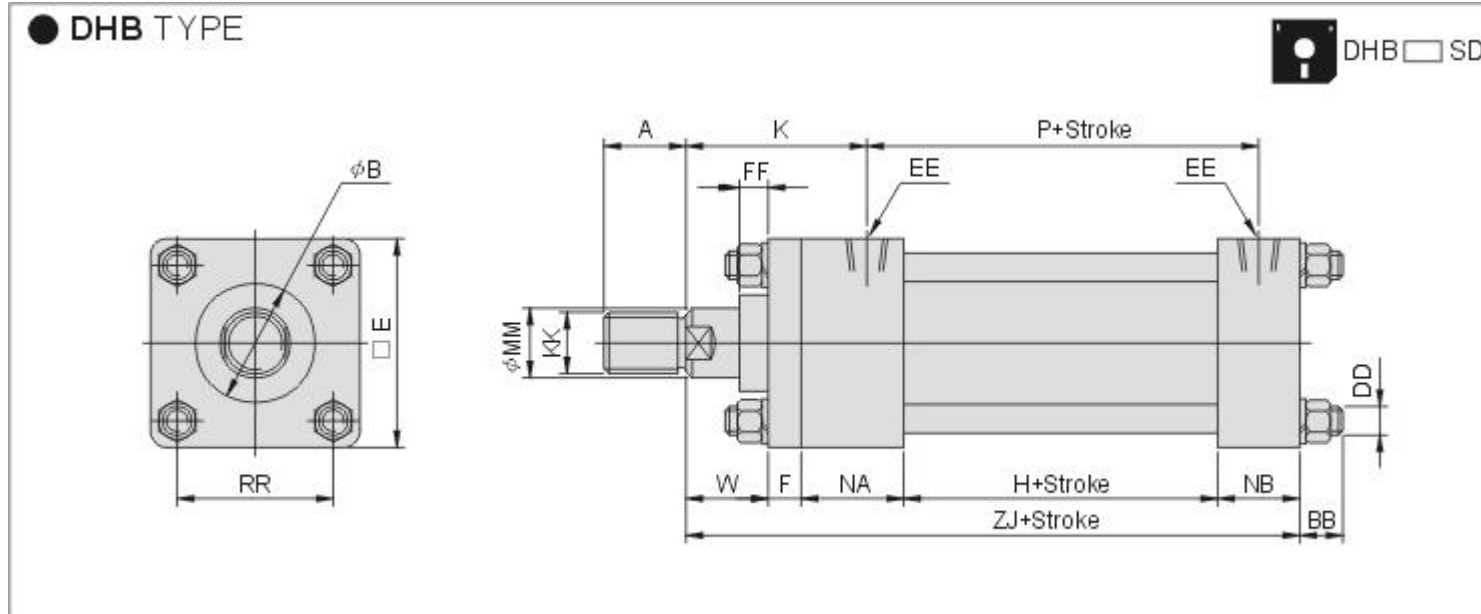

Dimensional Table

Bore	A	B	BB	DD	E	EE	F	FF	H	K	KK	MM	NA	NB	P	RR	W	ZJ
φ40	30	35	16	M 10 x 1.25	65	PT 1/4	11	11	60	60	M 16 x 1.5	20	36	26	84	45	25	158
φ50	35	40	16	M 10 x 1.25	75	PT 3/8	13	9	60	66	M 22 x 1.5	25	42	34	88	52	25	174
φ63	40	50	18	M 12 x 1.5	90	PT 3/8	15	9	65	73	M 30 x 1.5	35	42	34	93	63	30	186

φ80	45	55	18	M 16 x 1.5	110	PT 1/2	18	7	65	79	M 30 x 1.5	40	46	39	95	80	30	198
φ100	50	65	25	M 18 x 1.5	135	PT 1/2	20	7	74	95	M 40 x 2.0	50	50	40	104	102	40	224
φ125	60	75	30	M 22 x 1.5	165	PT 3/4	25	7	74	109	M 48 x 2.0	60	58	47	112	122	45	249
φ150	70	95	30	M 26 x 1.5	195	PT 3/4	30	7	90	119	M 72 x 2.0	80	58	48	128	148	50	276

安裝配件尺寸 Accessories

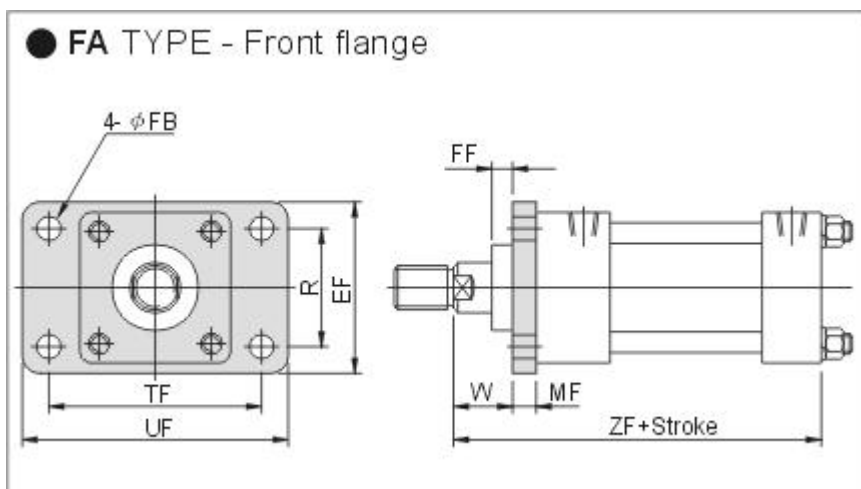

Dimensional Table



Bore	EF	FB	FF	MF	R	TF	UF	W	ZF
φ40	69	11	11	11	46	95	118	25	158
φ50	85	11	9	13	58	115	145	25	174
φ63	98	14	9	15	65	132	165	30	186
φ80	118	18	7	18	87	155	190	30	198
φ100	150	22	7	20	109	190	230	40	224
φ125	175	24	7	25	130	224	272	45	249
φ150	210	28	7	30	155	270	320	50	276

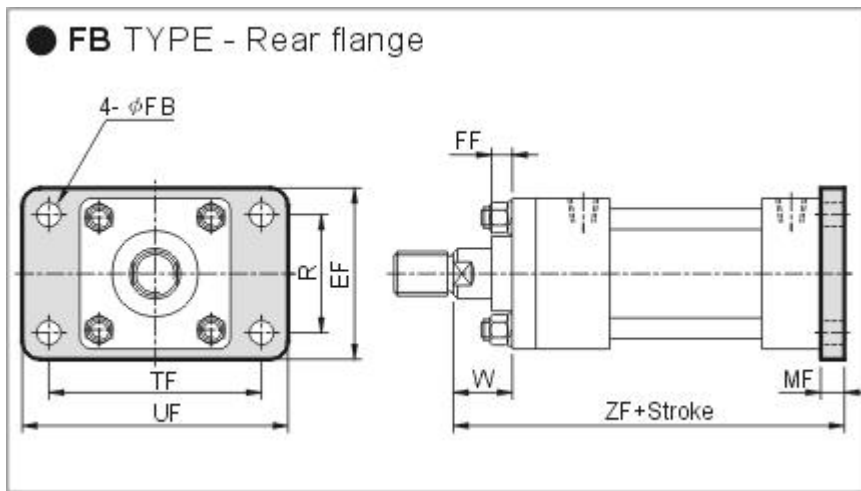

Dimensional Table



Bore	EF	FB	FF	MF	R	TF	UF	W	ZF
φ40	69	11	11	11	46	95	118	25	169
φ50	85	11	9	13	58	115	145	25	187
φ63	98	14	9	15	65	132	165	30	201
φ80	118	18	7	18	87	155	190	30	216
φ100	150	22	7	20	109	190	230	40	244
φ125	175	24	7	25	130	224	272	45	274
φ150	210	28	7	30	155	270	320	50	306

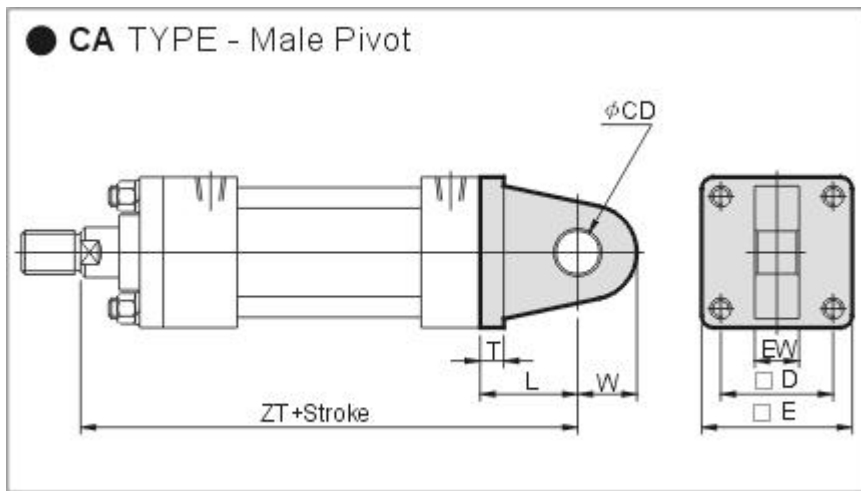

Dimensional Table



Bore	CD	D	E	EW	L	T	W	ZT
φ40	16	45	65	20	38	11	25	196
φ50	20	52	75	25	45	13	25	219
φ63	25	63	90	30	54	15	30	240
φ80	30	80	110	35	71	18	30	269
φ100	40	102	135	40	86	20	40	310
φ125	50	122	165	50	110	25	45	359
φ150	60	148	195	60	109	30	50	385

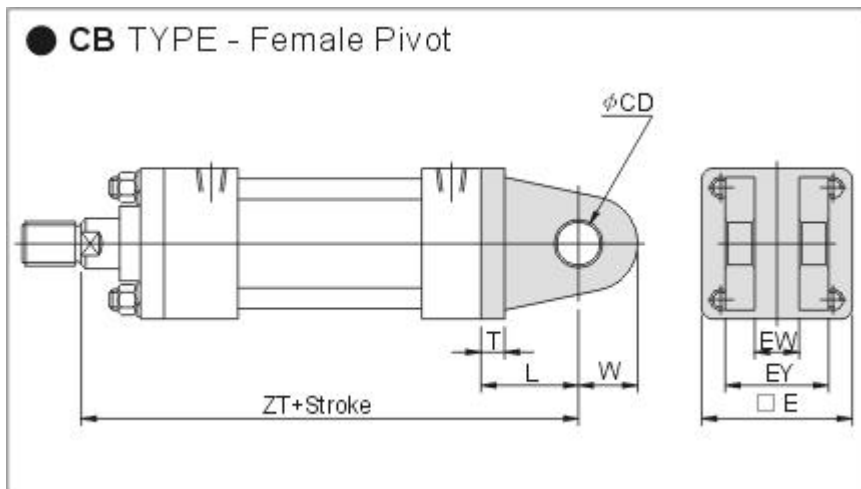

Dimensional Table



Bore	CD	E	EW	EY	L	T	W	ZT
φ40	16	65	20	50	38	11	25	196
φ50	20	75	25	57	45	13	25	219
φ63	25	90	30	70	54	15	30	240
φ80	30	110	35	80	71	18	30	269
φ100	40	135	40	100	86	20	40	310
φ125	50	165	50	126	110	25	45	359
φ150	60	195	60	160	109	30	50	385

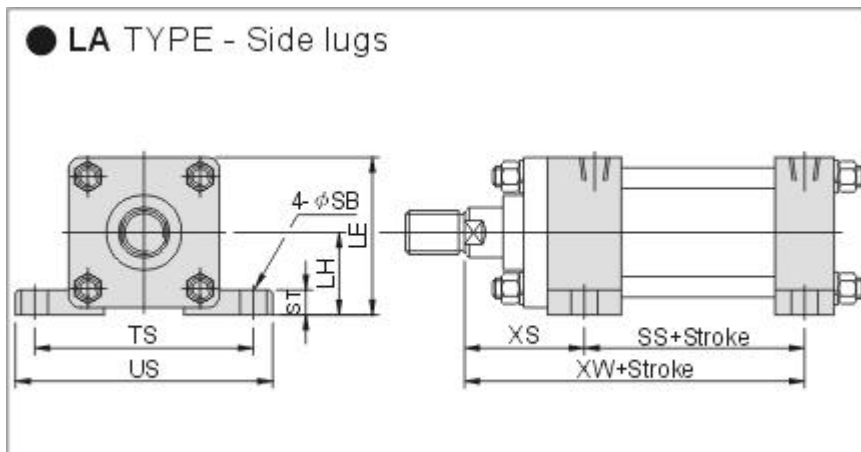

Dimensional Table



Bore	LE	LH	SB	SS	ST	TS	XS	XW	US
φ40	70	37.5	11	91	14	95	54	145	118
φ50	82.5	45	11	98	17	115	59	157	145
φ63	95	50	14	103	19	132	66	169	165
φ80	115	60	18	107.5	25	155	71	178.5	190
φ100	138.5	71	22	119	27	190	85	204	230

ϕ 150	203.5	106	28	143	37	270	109	252	320
------------	-------	-----	----	-----	----	-----	-----	-----	-----

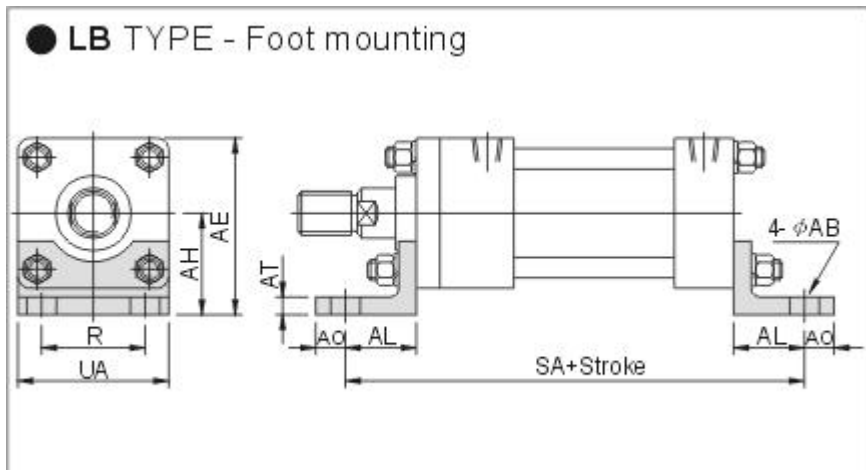

Dimensional Table



Bore	AB	AE	AH	AL	AO	AT	R	SA	UA
ϕ 40	11	75.5	43	32.5	13	8	46	198	69
ϕ 50	11	87.5	50	32.5	15	8	58	214	75
ϕ 63	14	105	60	37	18	10	65	230	90
ϕ 80	18	127	72	49	20	12	87	266	110
ϕ 100	22	152.5	85	58	23	12	109	300	135
ϕ 125	24	187.5	105	68.5	29	15	130	341	165
ϕ 150	28	220.5	123	74.5	30	18	155	375	195

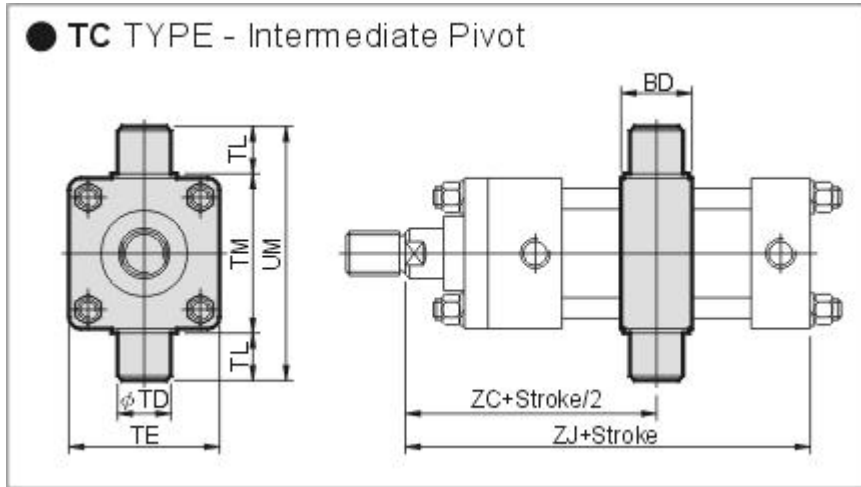

Dimensional Table



Bore	BD	TE	TD	TL	TM	UM	ZC	ZJ
φ40	28	65	20	20	69	109	102	158
φ50	33	75	25	25	85	135	110	174
φ63	38	90	30	30	98	158	119.5	186
φ80	38	110	30	30	118	178	126.5	198
φ100	48	135	40	40	145	225	147	224
φ125	58	165	50	50	175	275	165	249
φ150	73	195	60	63	205	331	183	276

軸端配件尺寸 Accessories

Dimensional Table



Type	Bore	CA	CC	CD	CF	CT	FW	KK	RA	RF	File name
Y-M 16 x1.5	∅40	50	26	16	35	45	20	M 16x1.5	66	24	YM 16150H
Y-M 22 x1.5	∅50	60	30	20	40	50	25	M 22x1.5	80	30	YM 22150H
Y-M 30 x1.5	∅63	80	40	25	50	60	30	M 30x1.5	105	40	YM 30150H
Y-M 30 x1.5	∅80	80	40	30	60	65	35	M 30x1.5	110	40	YM 30150H
Y-M 40 x2.0	∅100	90	50	40	80	90	40	M 40x2.0	130	40	YM 40200H
Y-M 48 x2.0	∅125	110	60	50	100	100	50	M 48x2.0	160	50	YM 48200H
Y-M 72 x2.0	∅150	130	70	60	120	120	60	M 72x2.0	190	60	YM 72200H

● 軸銷 Pin

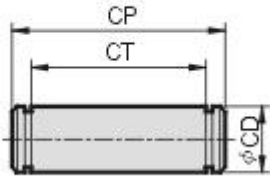

Dimensional Table



Type	Bore	CD	CP	CT	File name
P1659	φ40	16	59	46	P16059
P2066	φ50	20	66	51	P20066
P2576	φ63	25	76	61	P25076
P3081	φ80	30	81	66	P30081
P40114	φ100	40	114	91	P40114
P50124	φ125	50	124	101	P50124
P60156	φ150	60	156	121	P60156

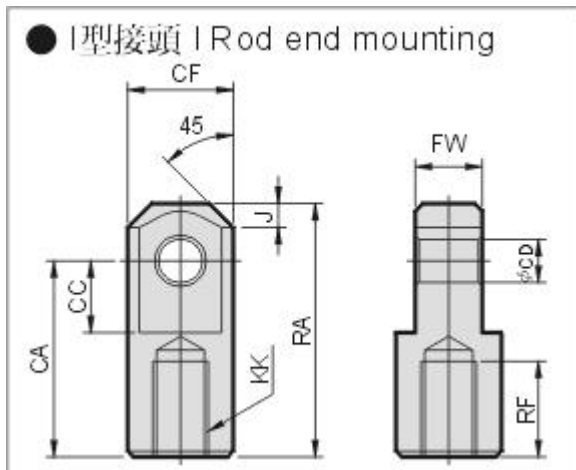

Dimensional Table



Type	Bore	CA	CC	CD	CF	FW	J	KK	RA	RF	File name
I-M 16 x1.5	φ40	55	30	16	40	20	8	M 16x1.5	75	20	IM_16150H
I-M 22 x1.5	φ50	65	35	20	50	25	10	M 22x1.5	90	25	IM_22150H
I-M 30 x1.5	φ63	80	40	25	55	30	12.5	M 30x1.5	110	35	IM_30150H
I-M 30 x1.5	φ80	90	45	30	60	35	15	M 30x1.5	125	35	IM_30150H
I-M 40 x2.0	φ100	105	55	40	80	40	20	M 40x2.0	145	40	IM_40200H
I-M 48 x2.0	φ125	120	65	50	100	50	30	M 48x2.0	170	50	IM_48200H
I-M 72 x2.0	φ150	140	75	60	120	60	30	M 72x2.0	200	55	IM_72200H

● 軸牙螺帽 Mounting nut

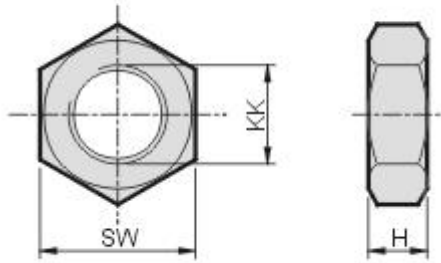

Dimensional Table



Type	Bore	H	KK	SW	File name
N-M 16 x1.5	φ40	8	M 16x1.5	24	NM 16150H
N-M 22 x1.5	φ50	11	M 22x1.5	32	NM 22150H
N-M 30 x1.5	φ63	13	M 30x1.5	41	NM 30150H
N-M 30 x1.5	φ80	13	M 30x1.5	41	NM 30150H
N-M 40 x2.0	φ100	15	M 40x2.0	57	NM 40200H
N-M 48 x2.0	φ125	15	M 48x2.0	65	NM 48200H
N-M 72 x2.0	φ150	20	M 72x2.0	100	NM 72200H