

油壓缸油壓標準型

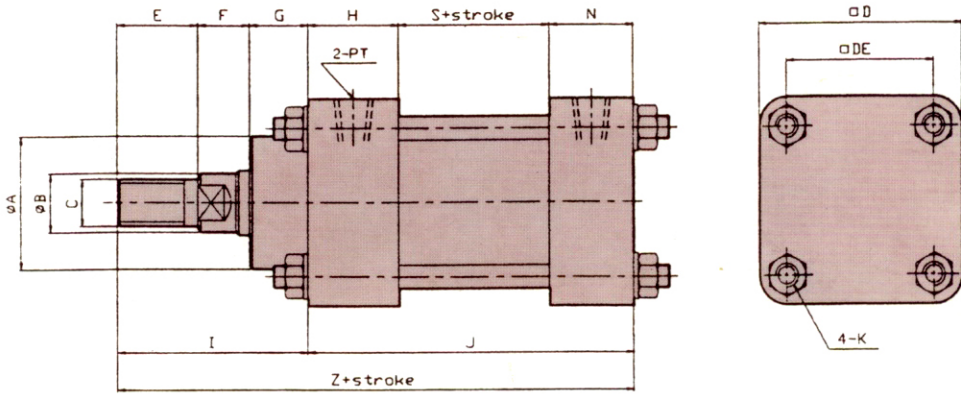

SIZE BORE	ϕA	ϕB	C	$\square D$	$\square DE$	E	F	G	H	N	I	J	K	S	Z	PT
$\phi 30$	30	16	M14XP1.5	50	34	28	10	15	25	25	53	100	M8XP1.25	50	153	1/4
$\phi 40$	40	20	M16XP1.5	64	45	28	17	20	30	30	65	110	M8XP1.25	50	175	3/8
$\phi 50$	45	20	M16XP1.5	70	50	28	17	20	30	28	65	108	M10XP1.25	50	173	3/8
$\phi 63$	55	25	M22XP1.5	85	60	40	20	30	31	31	90	112	M10XP1.25	50	202	3/8
$\phi 80$	62	30	M26XP1.5	106	74	40	20	32	37	35	92	127	M12XP1.5	55	219	1/2
$\phi 100$	78	35	M30XP1.5	122	89	45	20	32	37	37	97	154	M14XP1.5	80	251	1/2
$\phi 125$	85	50	M40XP2.0	147	110	55	25	31	40	40	111	160	M16XP1.5	80	271	1/2

油壓 CA 型

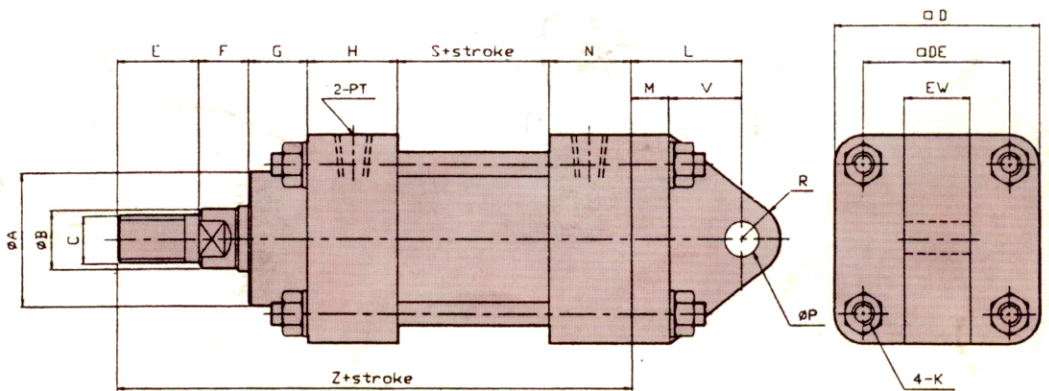

SIZE BORE	ϕA	ϕB	C	$\square D$	$\square DE$	E	F	G	H	N	L	M	V	ϕP	R	EW	K	S	Z	PT
$\phi 30$	30	16	M14XP1.5	50	34	28	10	15	25	25	28	8	20	10	10	8	M8XP1.25	50	181	1/4
$\phi 40$	40	20	M16XP1.5	64	45	28	17	20	30	30	37	12	25	12	13	22	M8XP1.25	50	212	3/8
$\phi 50$	45	20	M16XP1.5	70	50	28	17	20	30	28	37	12	25	12	13	22	M10XP1.25	50	210	3/8
$\phi 63$	55	25	M22XP1.5	85	60	40	20	30	31	31	50	19	31	20	24	30	M10XP1.25	50	252	3/8
$\phi 80$	62	30	M26XP1.5	106	74	40	20	32	37	35	65	15	50	30	30	30	M12XP1.5	55	284	1/2
$\phi 100$	78	35	M30XP1.5	122	89	45	20	32	37	37	70	15	55	35	35	35	M14XP1.5	80	321	1/2
$\phi 125$	85	50	M40XP2.0	147	110	55	25	31	40	40	75	20	55	35	35	35	M16XP1.5	80	346	1/2