

# 重油 LA 型

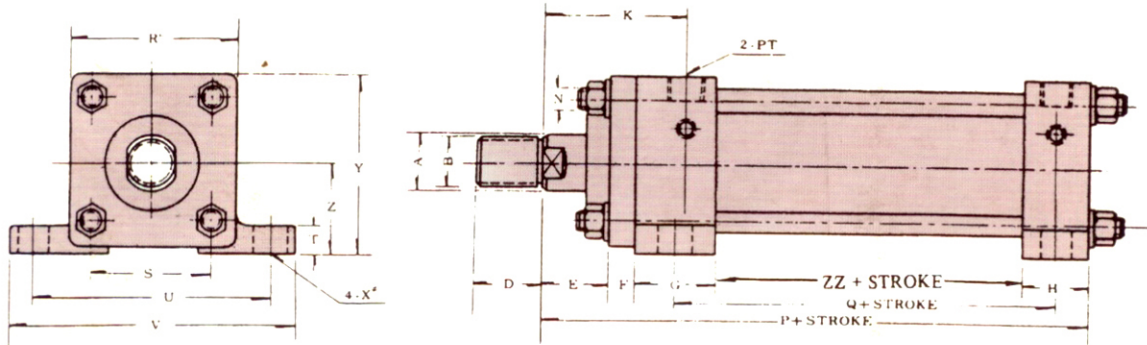

Cylinder Bore dia	A	B	C	D	E	F	G	H	K	N	P	Q	R	S	T	U	V	X	Y	Z	PT	ZZ
40	20	M18 P1.5 5/8 x 18	33	30	30	11	33	26	60	3/8	146	72	65	45	14	95	118	11	70	37.5	1/4	46
50	25	M22 P1.5 7/8 x 14	38	35	30	11	38	30	63	3/8	155	74	75 80	52	17	110	132	11	80	42.5	3/8	46
63	30	M26 P1.5 1 x 12	43	40	35	12	38	30	71	1/2	161	74	90	63	19	128	154	14	95	50	3/8	46
80	40	M36 P1.5 1 1/4 x 12	53	45	35	14	38	30	73	5/8	172	83	110 116	80	25	152	184	18	115	60	1/2	55
100	50	M40 P2.0 45 x 12	63	50	40	15	45	34	87	5/8	194	88	135	102	27	178	210	18	140	72.5	1/2	60
125	60	M50 P2.0 55 x 12	75	60	45	18	49	39	90	3/4	231	116	165	122	32	211	250	22	172.5	90	3/4	80
150	70	M60 P2.0 65 x 12	85	70	50	20	49	41	98	7/8	240	121	190 195	148	37	255	300	25	202.5	95	3/4	80
180	90	M80 P2.0 85 x 12	106	80	55	22	54	44	100	1"	270	138	235	182	47	295	340	25	242.5	125	1"	95
200	100	M90 P2.0 95 x 12	120	80	55	25	54	44	110	1"	273	163	262	200	52	340	390	30	270	139	1"	95

# 重油 LB 型

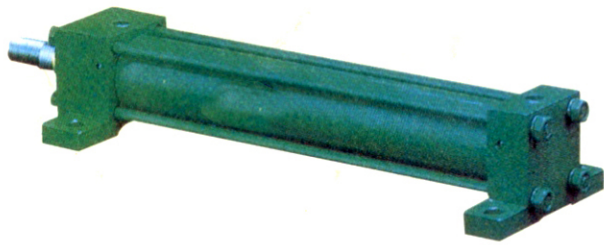
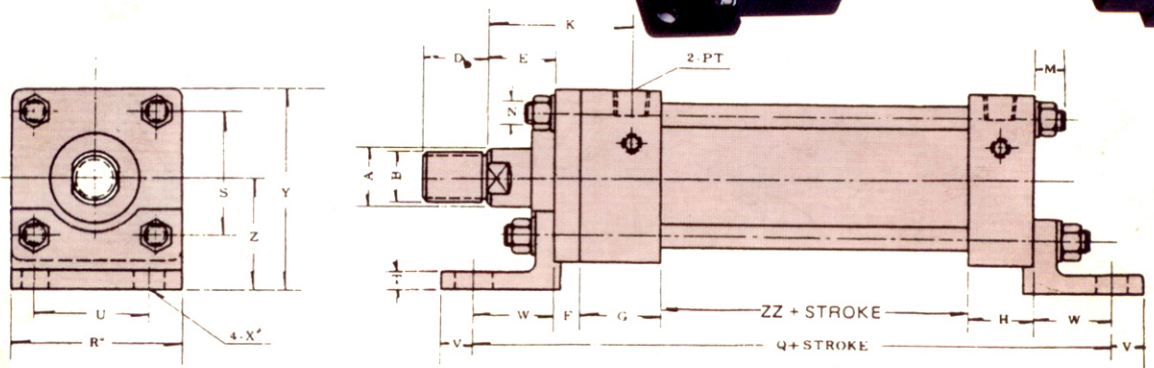
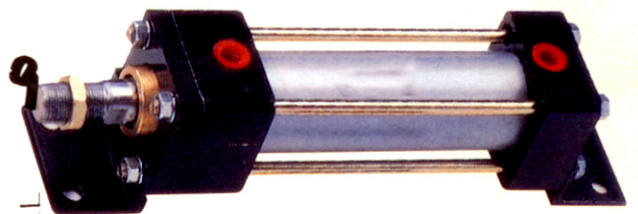

Cylinder Bore dia	A	B	C	D	E	F	G	H	K	N	Q	R	S	T	U	V	W	X	Y	Z	PT	ZZ
40	20	M18 P1.5 5/8 x 18	33	30	30	11	33	26	60	3/8	180	65	45	8	45	13	32	11	75.5	43	1/4	46
50	25	M22 P1.5 7/8 x 14	38	35	30	11	38	30	63	3/8	195	75 80	52	8	50	15	35	11	87.5	47.5	3/8	46
63	30	M26 P1.5 1 x 14	43	40	35	12	38	30	71	1/2	210	90	63	10	58	18	42	14	110	65	3/8	46
80	40	M36 P1.5 1 1/4 x 12	53	45	35	14	38	30	73	5/8	235	110 116	80	12	78	20	49	18	127	75	1/2	55
100	50	M40 P2.0 45 x 12	63	50	40	15	45	34	87	5/8	272	135	102	12	96	28	59	18	127	85	1/2	60
125	60	M50 P1.5 55 x 12	75	60	45	18	49	39	90	3/4	318	165	122	15	120	29	66	22	187.5	105	3/4	80
150	70	M60 P2.0 65 x 12	85	70	50	20	49	41	98	7/8	340	190 195	148	18	146	30	75	25	211	123	3/4	80
180	90	M80 P2.0 86 x 12	106	80	55	22	54	44	100	1"	385	235	182	20	180	40	85	25	265.5	148	1"	95
200	100	M90 P2.0 95 x 12	120	80	55	25	54	44	110	1"	414	262	200	25	200	40	98	30	296	165	1"	95